

2

1

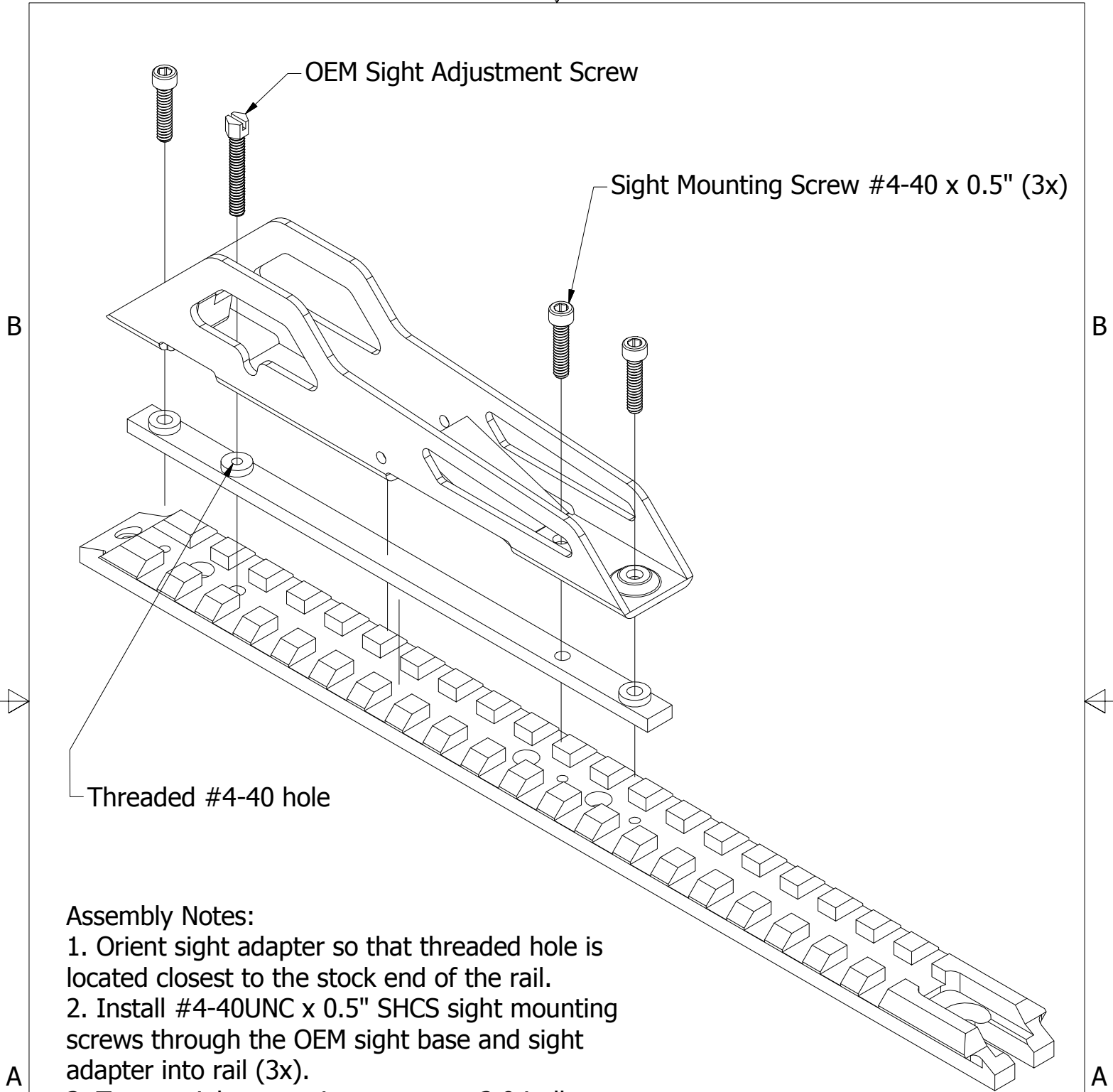

B

B

A

A

Threaded #4-40 hole

Assembly Notes:

1. Orient sight adapter so that threaded hole is located closest to the stock end of the rail.
2. Install #4-40UNC x 0.5" SHCS sight mounting screws through the OEM sight base and sight adapter into rail (3x).
3. Torque sight mounting screws to 2.9 in-lb maximum. Use blue thread locker if desired.
4. Install OEM sight adjustment screw and adjust height to nominal position.

Designed by K. Peck	Checked by	Approved by	Date	Date 12/16/2018	
 This design and derivatives are property of Peck's Anywhere. No unauthorized use of this material is permitted. All rights reserved.			SA-xx95TS-OEM Assembly		
			SA-xx95TS-OEM-ASSY	Edition 2	Sheet 1 / 1

2

1